

WEIGHT (LBS)	INDUCTANCE	LOSS (WATTS)
5	9 mH	20

ECO No	DESCRIPTION	REV BY	DATE
M8306	REDRAW IN SOLIDWORKS	JP	12/06/12

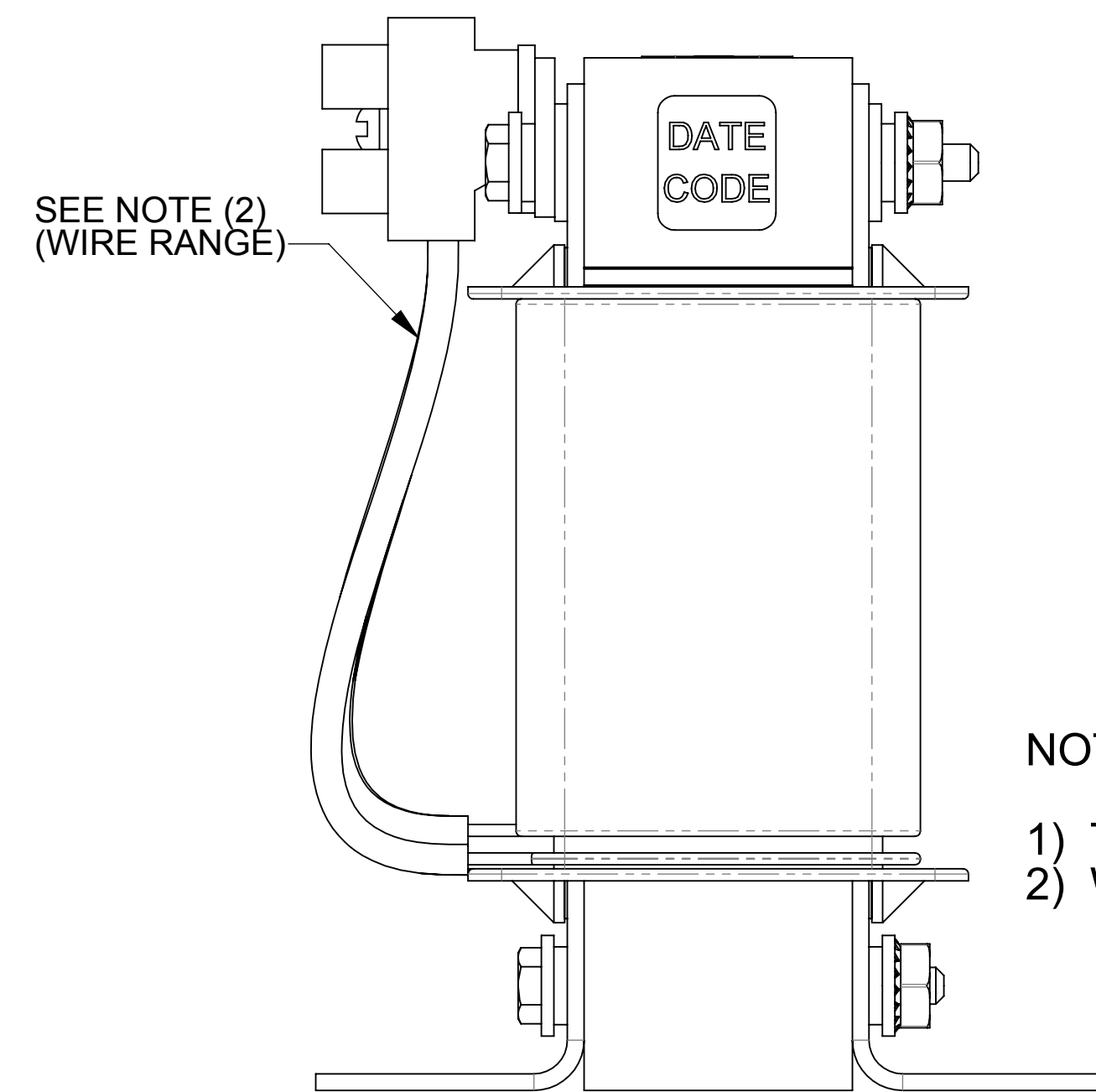
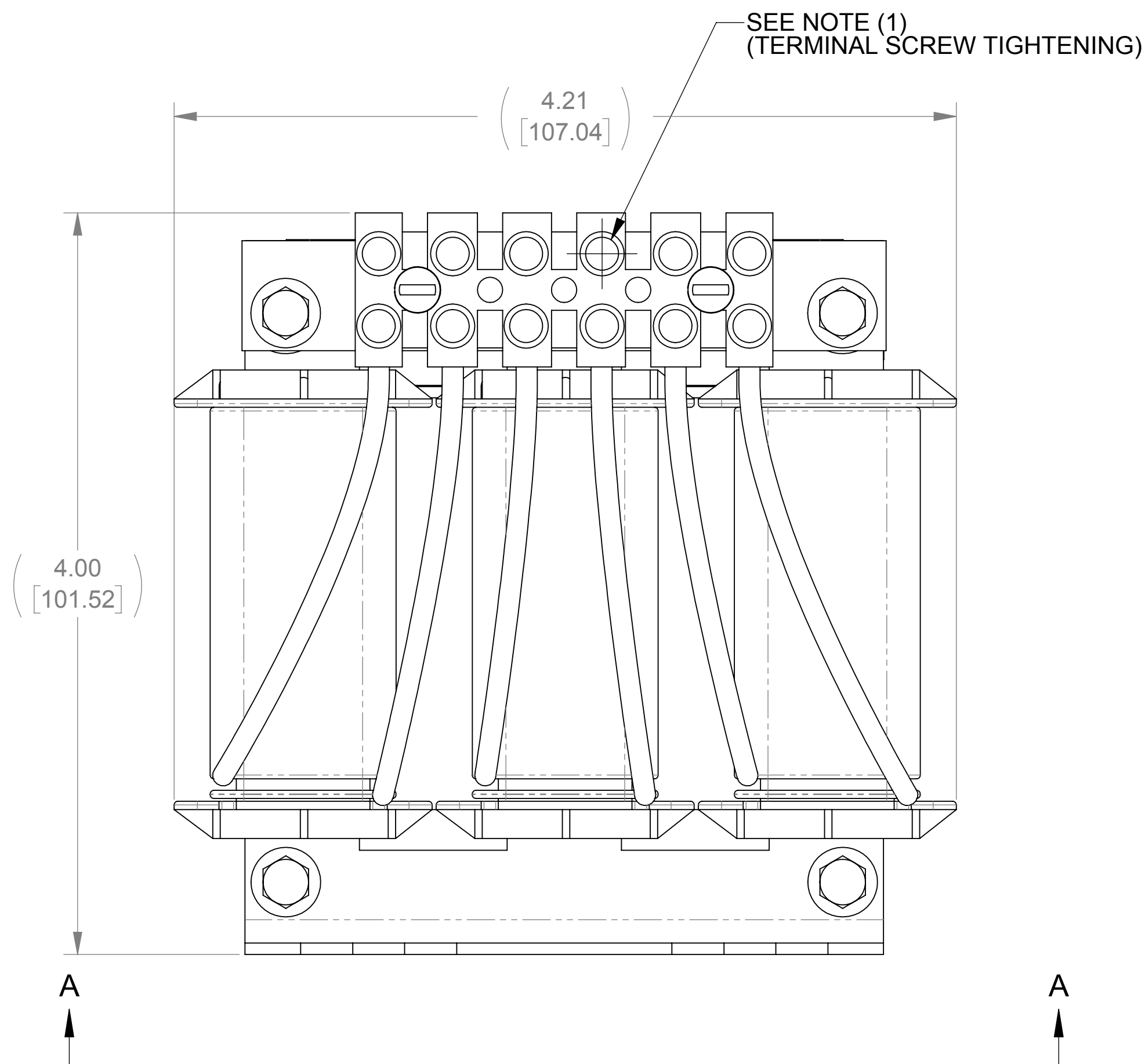
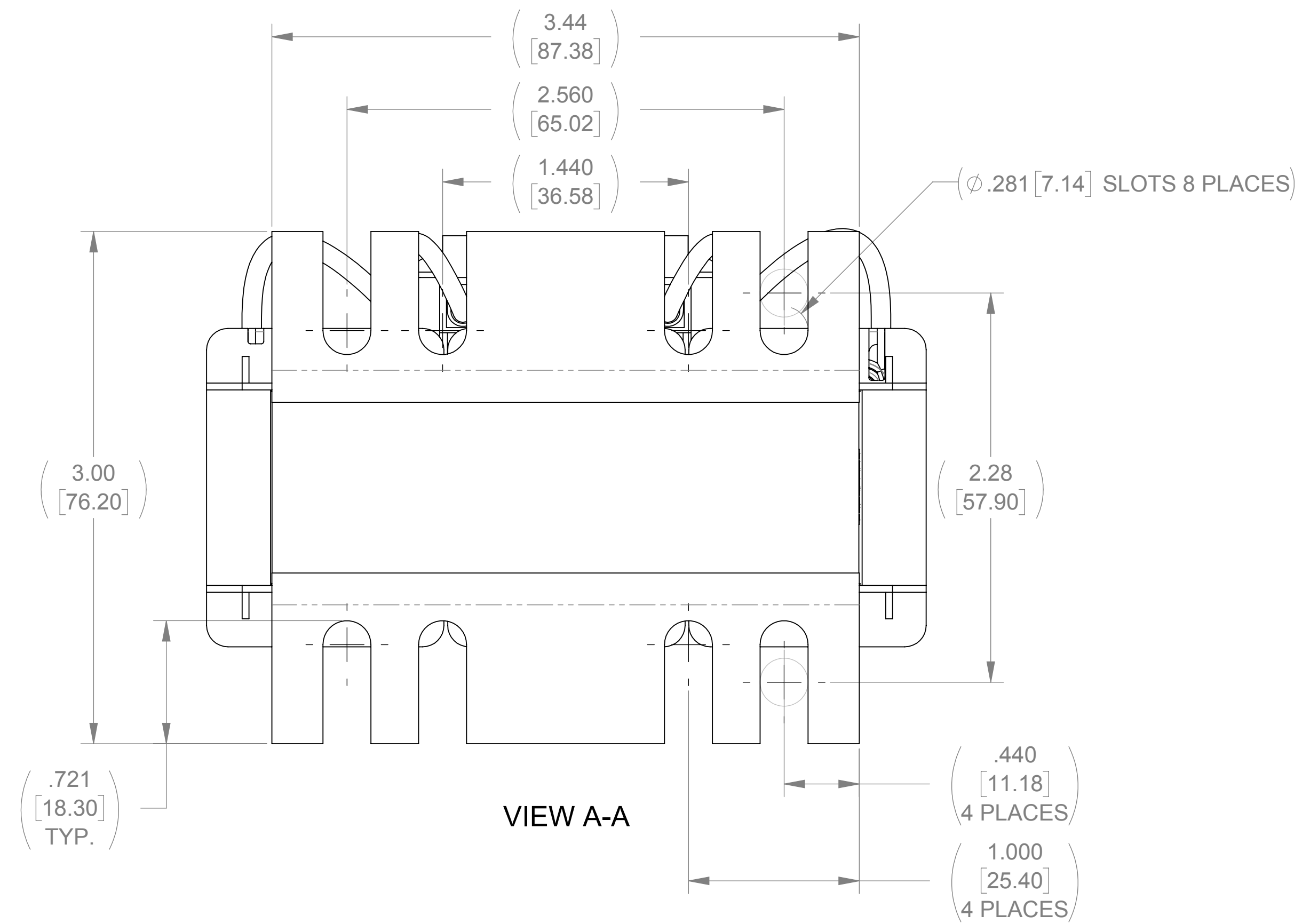
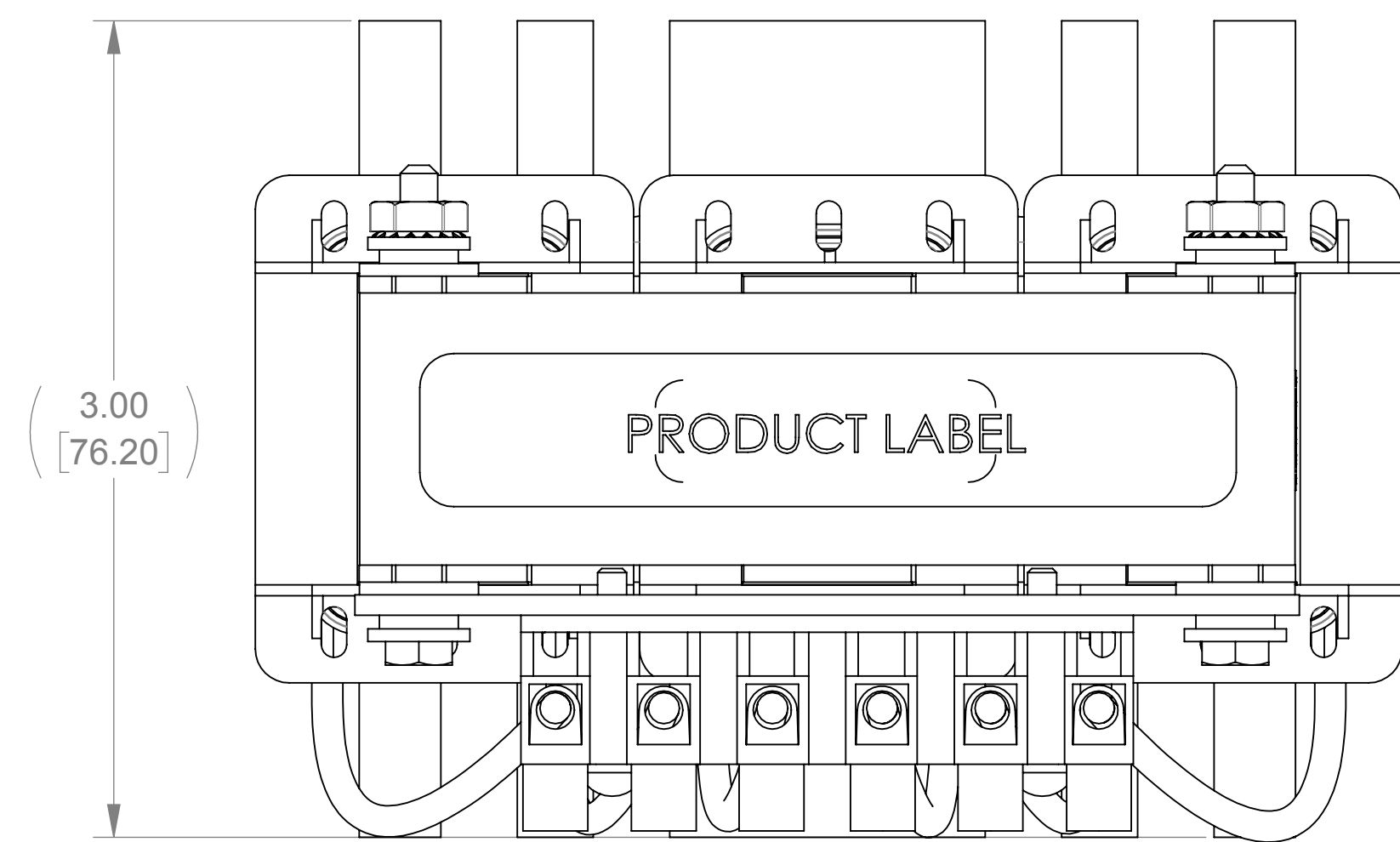

NOTES:

- 1) TERMINAL SCREW TIGHTENING TORQUE: 4.5 in-lbs MAX
- 2) WIRE RANGE: 22 - 10 AWG

<p>THE COMPONENT, PART OR ASSEMBLY DESCRIBED IN THIS DOCUMENT MUST COMPLY WITH THE EU (EUROPEAN UNION) DIRECTIVE RoHS</p> <p>CONTAINS <0.1% OF ANY SVHC BY WEIGHT PER REACH REGULATION</p> <p>UNLESS OTHERWISE SPECIFIED DIMENSIONS ARE IN INCHES [MM] TOLERANCES ARE:</p> <p>ANGLES: ± 1°</p> <p>1 PLACE .X: ± .1 [2.5]</p> <p>2 PLACE .XX: ± .03 [0.76]</p> <p>3 PLACE .XXX: ± .010 [0.254]</p>		<p>MATERIAL</p>		<p>CONFIDENTIAL AND PROPRIETARY INFORMATION</p> <p>THIS DOCUMENT CONTAINS CONFIDENTIAL AND PROPRIETARY INFORMATION OF MTE CORPORATION AND MAY NOT BE USED, COPIED OR DISCLOSED TO OTHERS EXCEPT WITH THE AUTHORIZED WRITTEN PERMISSION OF MTE CORPORATION</p>													
<p>MTE AN ILLINOIS POWER ELECTRONICS COMPANY</p> <p>N83 W13330 Leon Road Menomonee Falls, WI 53051 USA 800.455.4683 262.253.8200</p>		<table border="1"> <tr> <td>DRAWN</td> <td>DATE</td> </tr> <tr> <td>PB</td> <td>06/09/97</td> </tr> <tr> <td>CHECKED</td> <td>DATE</td> </tr> <tr> <td>TM</td> <td>12/13/12</td> </tr> <tr> <td>APPROVED</td> <td>DATE</td> </tr> <tr> <td>TM</td> <td>12/13/12</td> </tr> </table>		DRAWN	DATE	PB	06/09/97	CHECKED	DATE	TM	12/13/12	APPROVED	DATE	TM	12/13/12	<p>DESCRIPTION</p> <p>3 PHASE REACTOR</p>	
DRAWN	DATE																
PB	06/09/97																
CHECKED	DATE																
TM	12/13/12																
APPROVED	DATE																
TM	12/13/12																
		<table border="1"> <tr> <td>SIZE</td> <td>DWG No.</td> <td>REV</td> </tr> <tr> <td>D</td> <td>CD RL-00403</td> <td>19</td> </tr> </table>		SIZE	DWG No.	REV	D	CD RL-00403	19								
SIZE	DWG No.	REV															
D	CD RL-00403	19															
		<table border="1"> <tr> <td>SCALE</td> <td>SHEET 1 OF 1</td> </tr> <tr> <td>5:3</td> <td></td> </tr> </table>		SCALE	SHEET 1 OF 1	5:3											
SCALE	SHEET 1 OF 1																
5:3																	