

ECO No	DESCRIPTION	REV BY	DATE
M7146	UPDATED TO MATCH REV 14 AD	RKT	8/4/10
M7158	INCLUDED MOUNTING FOOT IN DEPTH DIMENSION	RKT	8/13/10
M7363	CHG'D 1/4-20X1/2 TO X3/4 IN HARDWARE	RKT	3/23/11
M8863	REMOVE FILTER LABEL	RH	08/20/12

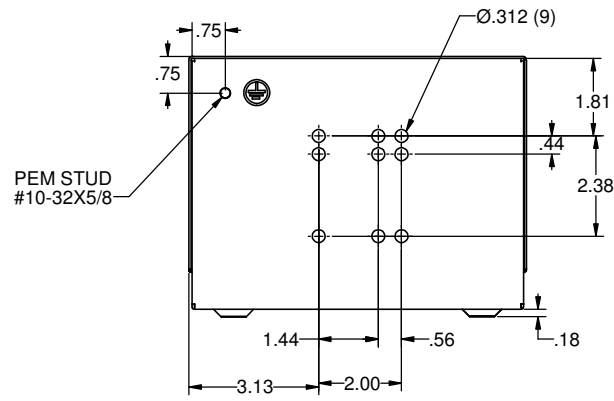
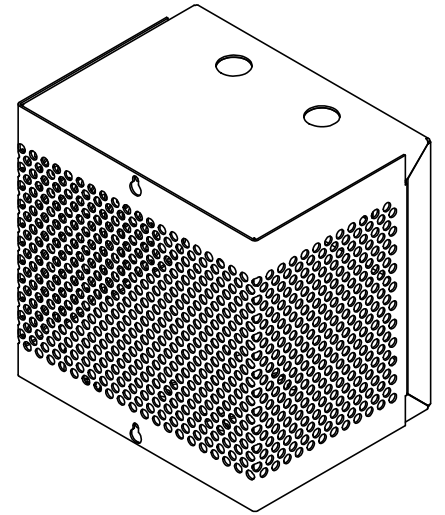
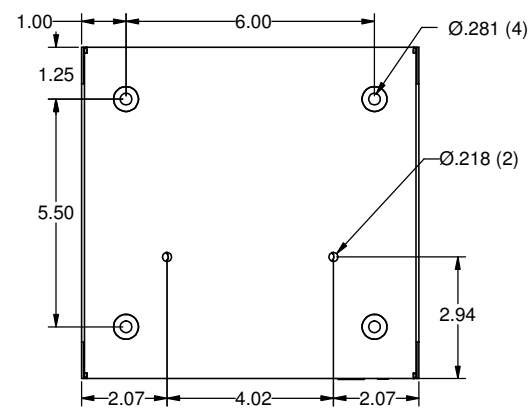
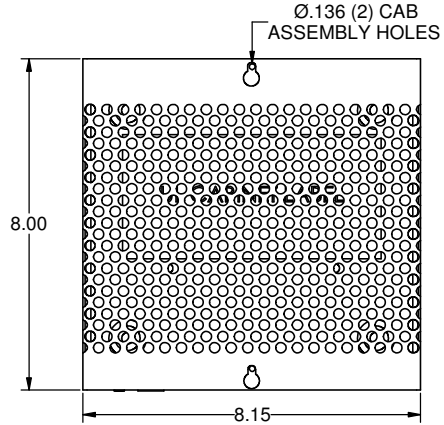
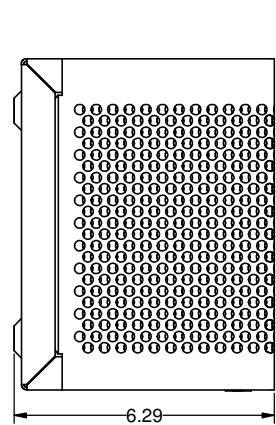
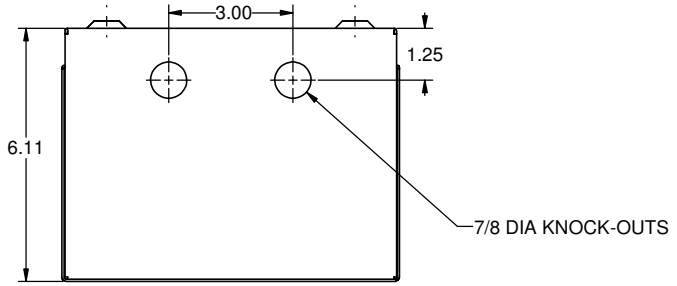

HARDWARE - LOCATED INSIDE ENCLOSURE

NUT 1/4-20 HEX STEEL ZINC PLATED	QTY 1
NUT 1/4-20 HEX STEEL ZINC PLATED	QTY 4
SCREW 1/4-20X3/4 HEX STEEL ZINC PLATED	QTY 4
WASHER 1/4 FLAT STEEL ZINC PLATED	QTY 8
WASHER 1/4 SPLITLOCK STEEL ZINC PLATED	QTY 4
WASHER #10 FLAT STEEL ZINC PLATED	QTY 3
WASHER #10 SPLITLOCK STEEL ZINC PLATED	QTY 3
NUT #10-32 HEX STEEL ZINC PLATED	QTY 3
SCREW #10-32X3/4 RH STEEL ZINC PLATED	QTY 2
SCREW #8-32X3/4 RH SLFT STL ZINC PLATED	QTY 2

THE COMPONENT PART OR ASSEMBLY DESCRIBED IN THIS DOCUMENT MUST COMPLY WITH THE EUROPEAN UNION DIRECTIVE RoHS CONTAINS <= 0.1% OF ANY SVHC BY WEIGHT PER REACH REGULATION		MATERIAL DRAWN: RH DATE: 08/08/12 CHECKED: JH DATE: 08/23/12 APPROVED: JH DATE: 08/23/12		CONFIDENTIAL AND PROPRIETARY INFORMATION THIS DOCUMENT CONTAINS CONFIDENTIAL AND PROPRIETARY INFORMATION OF MTE CORPORATION AND MAY NOT BE USED, COPIED OR DISCLOSED TO OTHERS EXCEPT WITH THE AUTHORIZED WRITTEN PERMISSION OF MTE CORPORATION	
UNLESS OTHERWISE SPECIFIED DIMENSIONS ARE IN INCHES (MM) TOLERANCES ARE: ANGLES: ± 1 ° 1 PLACE .X: ± .1 [2.5] 2 PLACE .XX: ± .03 [0.76] 3 PLACE .XXX: ± .010 [0.254]				DESCRIPTION CUSTOMER DRAWING	
				SIZE: D SCALE: 1:1.5	DWG No.: CD CAB-8 REV: 17