

WEIGHT (LBS)	INDUCTANCE	LOSS (WATTS)
34	1.2 mH	65

ECO No	DESCRIPTION	REV BY	DATE
M8650	UPDATED COILS, ROUTING	JT	07/19/13

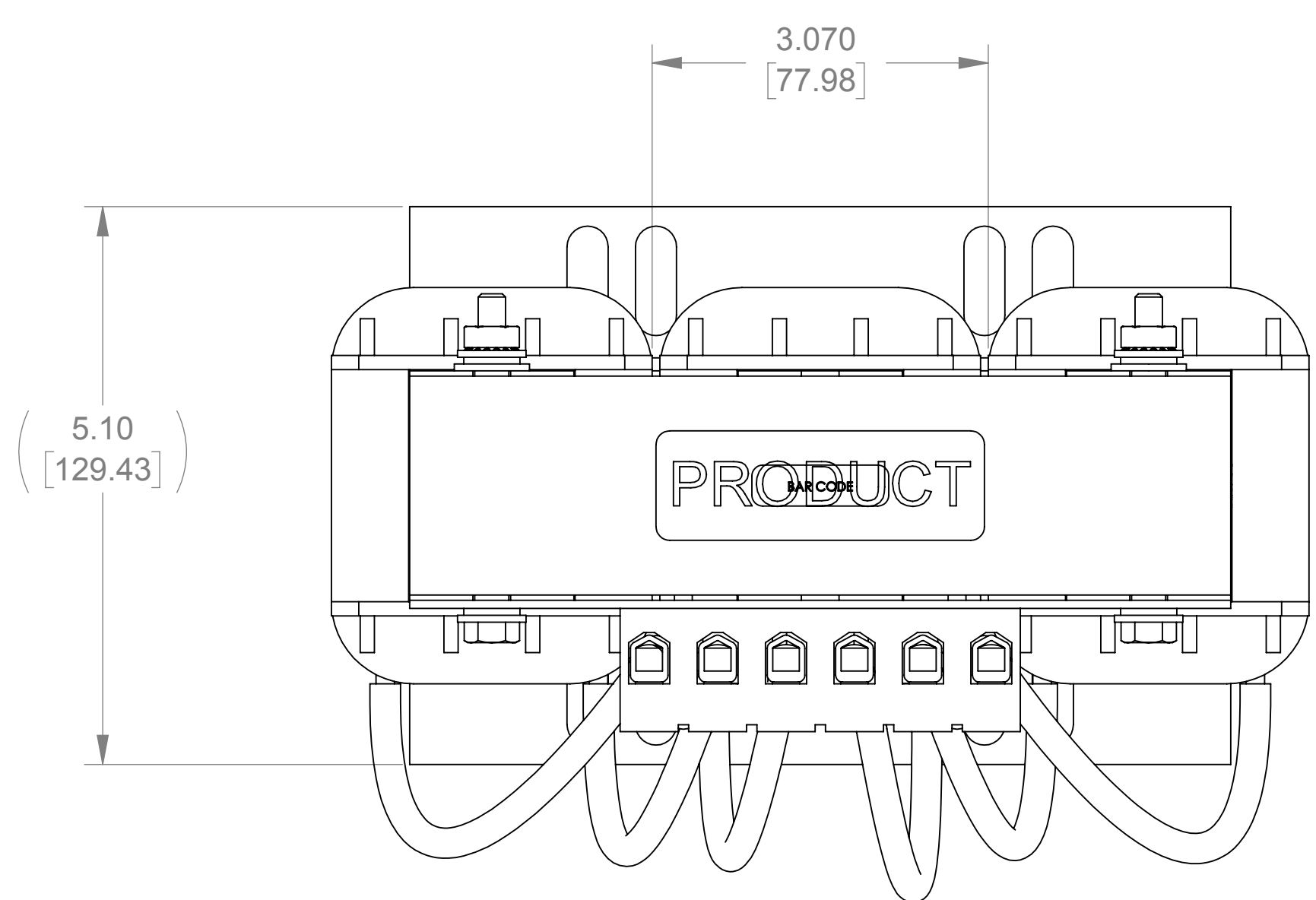

TOP VIEW

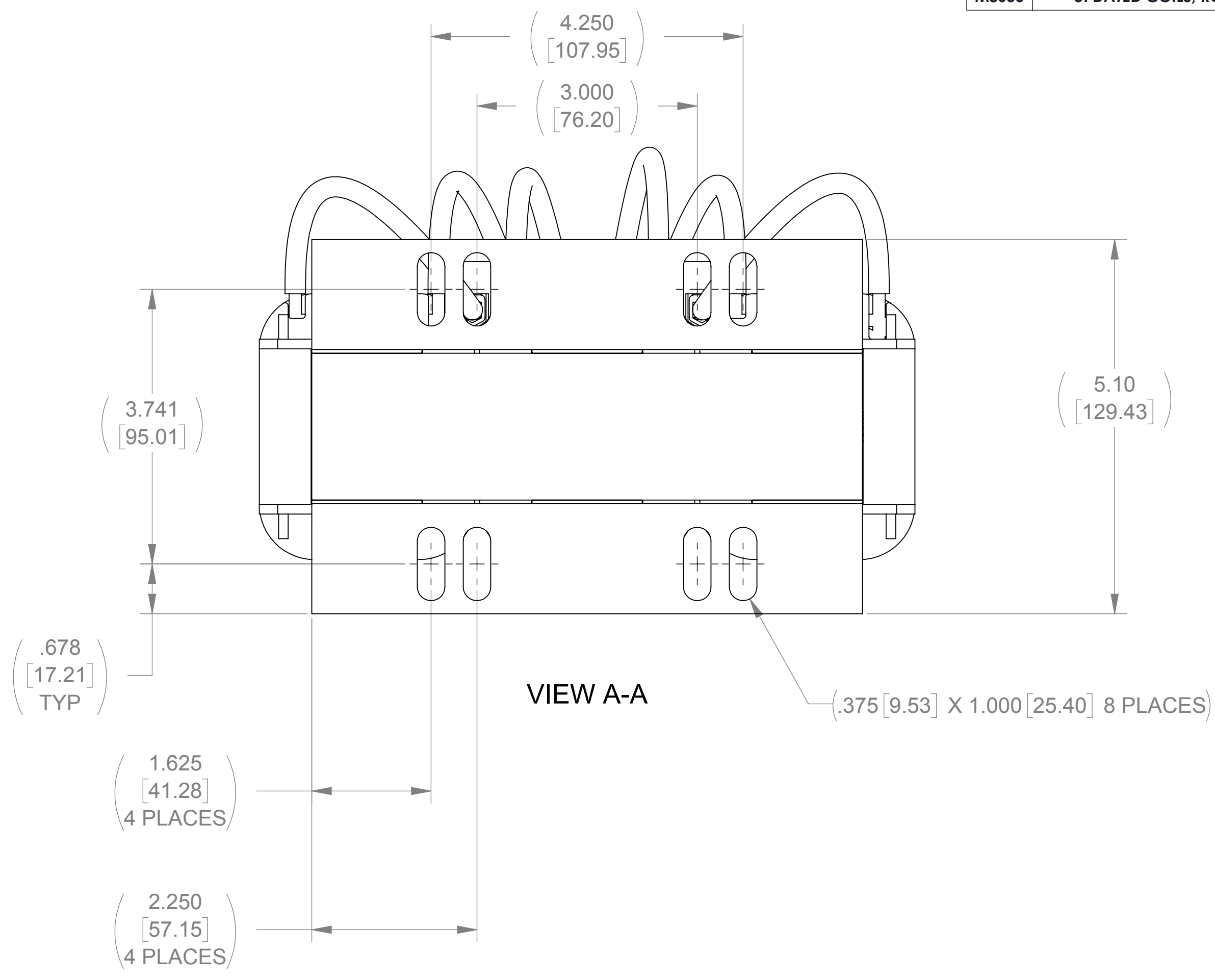

VIEW A-A

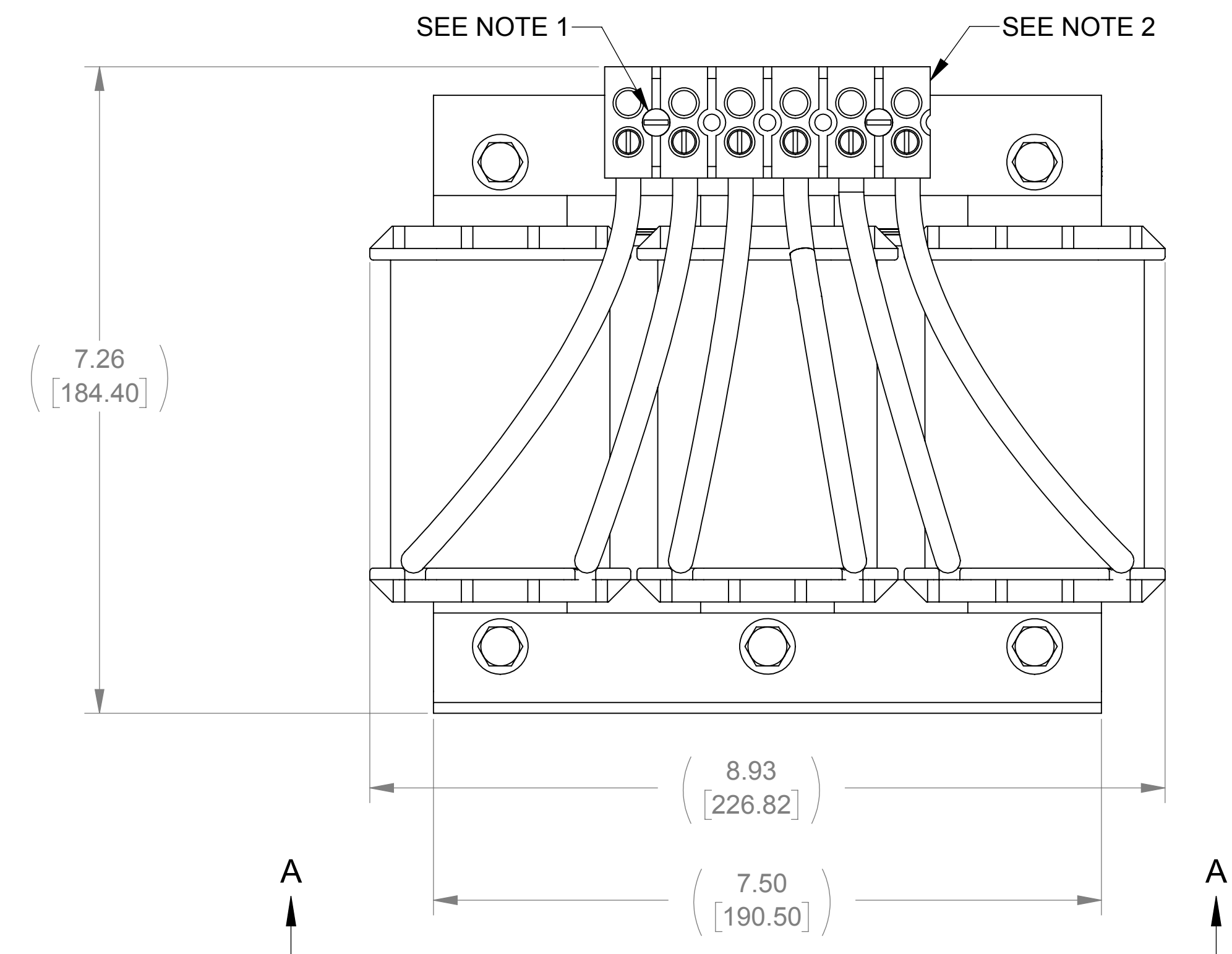

FRONT VIEW

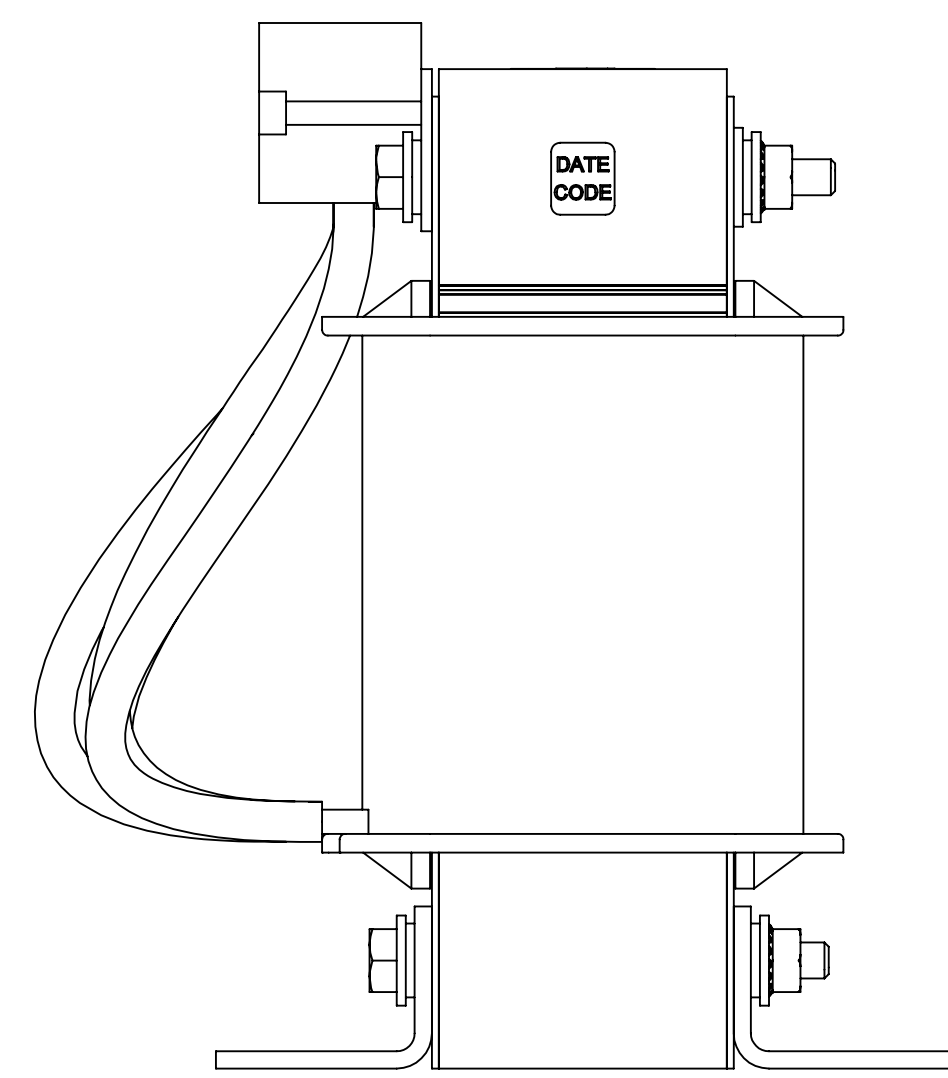

SIDE VIEW

- NOTES:
 1. TERMINAL SCREW TORQUE 16 IN-LBS MAX
 2. WIRE RANGE: 18-4 AWG

THE COMPONENT, PART OR ASSEMBLY DESCRIBED IN THIS DOCUMENT MUST COMPLY WITH THE EU (EUROPEAN UNION) DIRECTIVE RoHS CONTAINS <0.1% OF ANY SVHC BY WEIGHT PER REACH REGULATION		MATERIAL DRAWN BGS DATE 4/6/04 CHECKED RH DATE 07/22/13 APPROVED RH DATE 07/22/13	CONFIDENTIAL AND PROPRIETARY INFORMATION THIS DOCUMENT CONTAINS CONFIDENTIAL AND PROPRIETARY INFORMATION OF MTE CORPORATION AND MAY NOT BE USED, COPIED OR DISCLOSED TO OTHERS EXCEPT WITH THE AUTHORIZED WRITTEN PERMISSION OF MTE CORPORATION	
UNLESS OTHERWISE SPECIFIED DIMENSIONS ARE IN INCHES [MM] TOLERANCES ARE: ANGLES: ± 1° 1 PLACE .X: ± .1 [2.5] 2 PLACE .XX: ± .03 [0.76] 3 PLACE .XXX: ± .010 [0.254]			DESCRIPTION LINE/LOAD REACTOR	
MTE AN BL POWER ELECTRONICS COMPANY N83 W13330 Leon Road Menomonee Falls, WI 53051 USA 800.455.4683 262.253.8200		SIZE D SCALE 1:2	DWG No. CD RL-04503 REV 15	SHEET 1 OF 1